

MicroFLOW CH4 .10 Vol.-%

Inline NDIR gas sensor for measurement of methane and other hydrocarbons up to 10 vol.-%

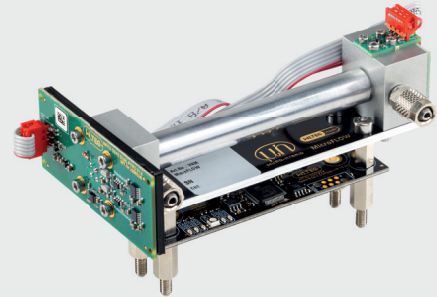

Applications

- Biogas plants: monitoring of processes in composting plants,
- Leakage monitoring in petrochemical plants,
- Monitoring of industrial emissions,
- Monitoring of environmental conditions

Product benefits

- Minimized deviation of pressure value and barometric changes (< 0.1 % / 10 hPa),
- Industrially most used interfaces available,
- Low maintenance due to high-quality material,
- Use in battery-powered devices,
- Gas temperature in the measuring system can be monitored,
- Maintenance and cleaning possible with little effort

Features

- 10 points linearization
- Pressure compensation by integrated pressure sensor
- Temperature compensation
- Digital interfaces RS232/ CAN-Bus,
- Robust design with high chemical resistance,
- Measurement of gas temperature possible,
- Modular design

Additional product information

The MicroFlow sensors are highly accurate and reliable, with 10-point linearization for optimal performance. They provide long-term stability and precision for the intended measuring range. These sensors are easy to use, ready-to-measure and can be quickly integrated into the application. The IR emitter ensures optimum signal quality. The integrated pressure sensor and sample cell block reduce the sensor module's space requirement and prevent errors caused by leakage.

The smart sensor design enables easy replacement of individual components. Low power consumption allows for use in battery-powered devices. A wide operational pressure range extends the range of applications, such as systems requiring negative pressure. Our software is available for free download. This saves time because no programming effort is required.

Online shop for IR components and sensors
Filter products simply by selecting the desired properties and request your quotation.

 microhybrid.com/shop



Technical data

Technical parameter	Unit	
General		
Order number	VKM2002979	
Measurement principle	NDIR	
Sample cell length	100	mm
Estimated lifetime of IR source	40 000	h
Gas flow rate	0,1 - 2	l/min
Dimensions	71 x 139 x 69.5	[mm]
Weight	170	g
Tube connection	6/4 mm tube	
Power supply connection	3 pol. RS232/ 3 pol. CAN-Bus (2.54 mm)	
Measurement ¹		
Measurement range	0 - 10	Vol.-%
Measuring gas	Methane	
Warm up time ²	< 10	min
Response time (t ⁹⁰)	< 2	s
Detection limit (3σ) ³	< 0.05	% FS
Digital resolution	0.001	Vol.-%
Linearity error	< 0.6	% FS
Repeatability	< 0.25	% FS
Long term stability (zero)	< 0.7	% FS/ month
Long term stability (span)	< 0.5	% FS/ month
Temperature influence (zero)	< 0.02	% FS/ 10 K
Temperature influence (span) ⁴	< 0.7	% FS/ 10 K
Position influence	< 0.5	% FS/ 180 °
Pressure influence	< 0.15	% FS/ 10 hPa

Technical data

Technical parameter		Unit
Electrical		
Operation voltage	9 ... 30	V DC
Operation current max.	45	mA
Nominal power consumption	1	W
Digital output signal	RS232 or CAN-Bus	
Output format CAN	MARS/ CAN-Bus	
Output format RS232	ASCII	
Data rate CAN max.	10	ms
Data rate RS232 max.	100	ms
Operating Environment		
Operation temperature ⁵	5 ... 45	°C
Storage temperature	-20 ... 60	°C
Air pressure	300 - 1 200	hPa
Ambient humidity	0 ... 95 % relative humidity (non condensing)	

¹ Zero gas for measurements: nitrogen; related to $P_a = 1020 \text{ hPa}$; $T_a = 25 \text{ °C}$; flow = 1 l/min

² Full specification, depends on environmental conditions

³ At zero point

⁴ With span temperature compensation

⁵ Stable climatic conditions recommended, please check dewpoint considerations

Mechanical drawings

Top view

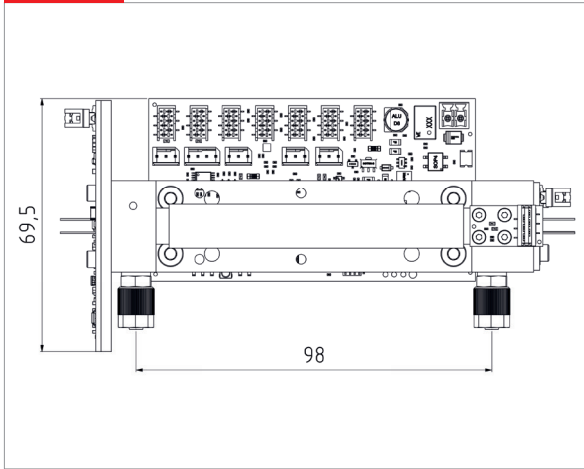

➔ All geometrical dimensions in mm

Front view

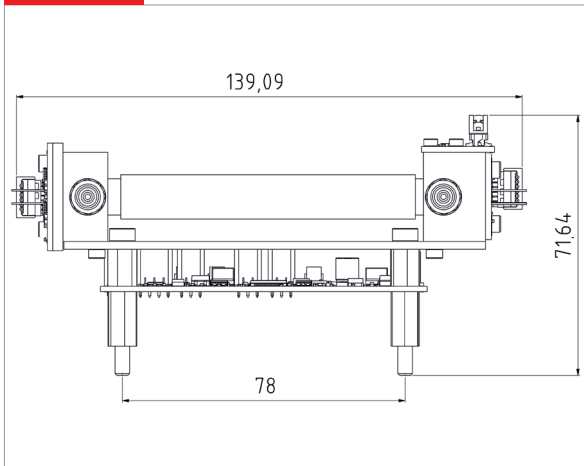

Side view

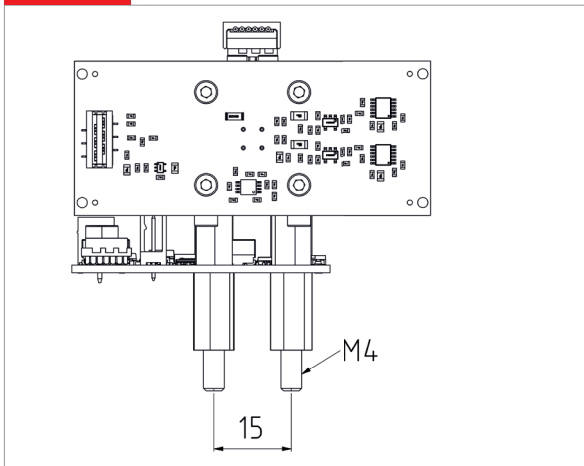

Product overview

Article number	Product name	Digital output signal	Measurement range
VKM2002977	MicroFLOW CO2.5000 ppm	CAN-Bus or RS232	0 ... 5 000 ppm
VKM2002978	MicroFLOW CH4.select 10 Vol.-%	CAN-Bus or RS232	0 ... 10 Vol.-%
VKM2002979	MicroFLOW CH4.10 Vol.-%	CAN-Bus or RS232	0 ... 10 Vol.-%
VKM2002980	MicroFLOW CO.50 Vol.-%	CAN-Bus or RS232	0 ... 50 Vol.-%
VKM2002981	MicroFLOW CO2.50 Vol.-%	CAN-Bus or RS232	0 ... 50 Vol.-%
VKM2002985	MicroFLOW SF6.100 Vol.-%	CAN-Bus or RS232	0 ... 100 Vol.-%

Wi.Tec inside



- Integrated pressure sensor μ P.sens
- Software MARS light
- Optimized for sample gas and gas concentration

Disclaimer

All rights reserved. All information in this data sheet are based on latest knowledge, results of practical experience and tests carried out. Earlier specifications are hereby invalid. All specifications – technical included – are subject to change without notice. It is the customer's responsibility to ensure that the performance of the product is suitable for customer's specific application. No liability is accepted for indirect damage, in particular for the use or inability to use the product. Any liability we may have is limited to the value of the product itself.